

EDDY

<p>It CARATTERISTICHE TECNICHE</p> <ul style="list-style-type: none"> > Dimensione max carico: 1250 x 1250 mm. > Dimensione min carico: 600 x 800 mm. > Altezza di avvolgimento STD: 2100 mm. > Velocità max. rotazione: LS:25 rpm HS:30 rpm HD:32 rpm > Altezza lavoro: 500 mm > Potenza totale installata: LS: 3,5Kw HS: 4,5 Kw HD : 5 Kw > Tensione alimentazione: 400V-50 Hz - 3F+N+T > Protezione macchina: IP54 > Pressione esercizio: 6bar. > Disponibilità di vari optional 	<p>En TECHNICAL FEATURES:</p> <ul style="list-style-type: none"> > Max load dimensions: 1250 x 1250 mm > Min load dimensions: 600 x 800 mm > STD Wrapping height: 2100 mm > Max. Rotation speed: LS:25 rpm HS:30 rpm HD:32 rpm > Working height:500 mm > Total installed power: LS: 3,5 Kw HS: 4,5 Kw HD: 5 Kw > Std. Power supply: 400V-50 Hz - 3PH+N+G > Machines protection: IP54 > Operating pressure: 6bar. > Various options available. 	<p>Fr CARACTERISTIQUES TECHNIQUES:</p> <ul style="list-style-type: none"> > Dimensions max palette: 1250 x 1250 mm > Dimensions min palette: 600 x 800 mm > Hauteur de banderolage STD: 2100 mm > Vitesse de rotation max LS:25 t/min. HS:30 t/min. HD:32 t/min. > Hauteur de travail :500 mm > Puissance totale installée : LS : 3,5 Kw HS : 4,5 Kw HD : 5 Kw > Tension alimentation std. 3 x 400V+N+T / 50Hz > Protection de la machine : IP 54 > Pression de travail: 6bar. > Différentes options disponibles. 	<p>De TECHNISCHE DATEN:</p> <ul style="list-style-type: none"> > Max Maße der palette: 1250 x 1250 mm > Min Maße der palette: 600 x 800 mm > STD Höhe der palette: 2100 mm > Drehgeschwindigkeit: LS:25 UpM HS:30 UpM HD:32 UpM > Bodenhöhe: 500 mm > Installierte Gesamtleistung LS : 3,5 Kw HS : 4,5 Kw HD : 5 Kw > Std.Versorgungsspannung: 400V-50 Hz - 3PH+N+G > Maschine Schutz: IP54 > Arbeits-Druckleistung: 6bar > Verschiedene Optionen zur Verfügung. 	<p>Es CARACTERÍSTICAS TÉCNICAS:</p> <ul style="list-style-type: none"> > Máx dimensiones del palet: 1250 x 1250 mm > Mini dimensiones del palet: 600 x 800 mm > Altura del palet STD: 2100 mm > Max. Rotation speed: LS:25 rpm HS:30 rpm HD:32 rpm > Working height: 500 mm > Total installed power: LS : 3,5 Kw HS : 4,5 Kw HD : 5 Kw > Std. Power supply: 400V-50 Hz - 3PH+N+G > Machines protection: IP54 > Operating pressure: 6bar > Varias opciones disponibles.
---	---	---	--	--

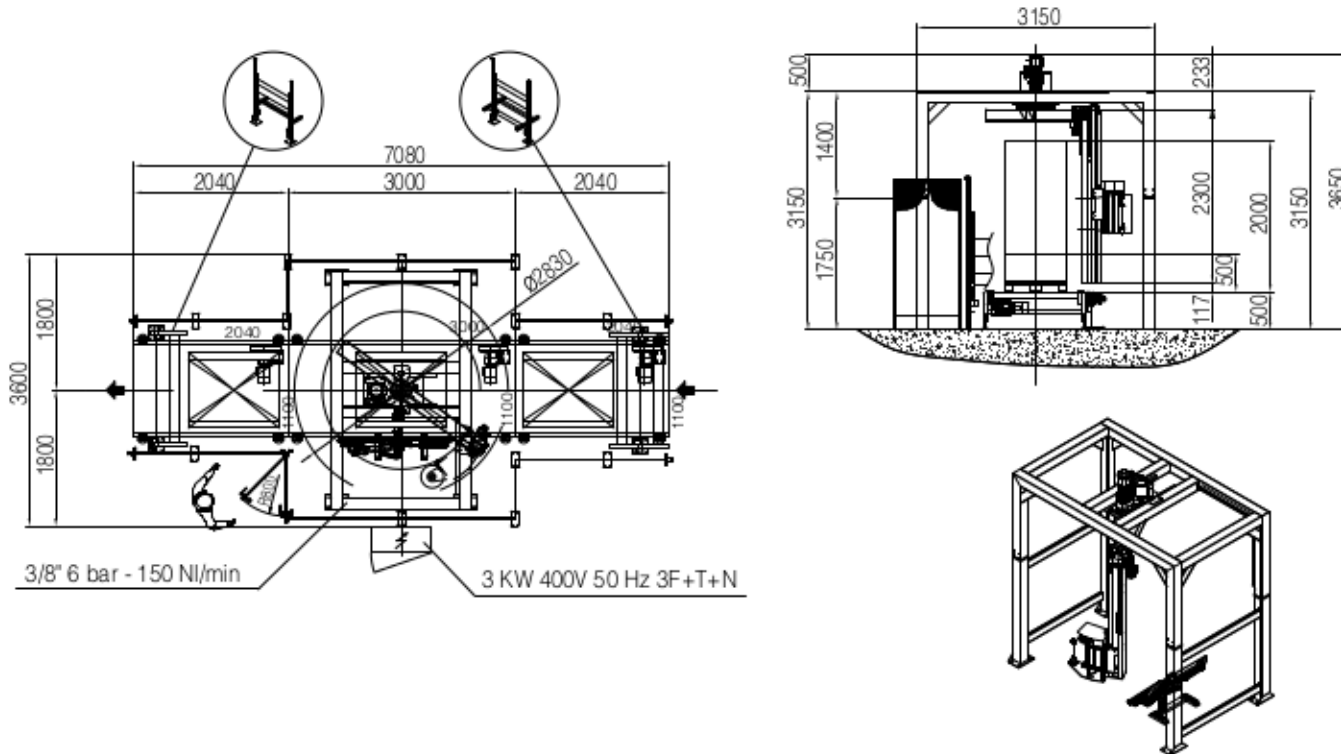

UN GRUPPO A DIFESA
DEI TUOI PRODOTTI

A GROUP IN DEFENSE
OF YOUR PRODUCTS

UN GROUPE POUR
PROTEGER VOS PRODUITS

EINE EINHEIT ZUM
SCHUTZ IHRER PRODUKTE

UN GRUPO EN DEFENSA
DE SUS PRODUCTOS

EDDY



It_ Le indicazioni riportate non sono impegnative.
En_ The information given is not binding.
Fr_ Les indications fournies ne sont pas contraignantes.
De_ Die Angaben sind unverbindlich.
Es_ Las indicaciones presentadas no nos comprometen.

 **SIRTEC S.r.l.**
Packaging innovation

 **SIRTEC S.r.l.**
Packaging innovation